

RoHS
Compliant

ZONE	ECN.N.O.	DESCRIPTION	DRAWING	DATE
A		INITIAL	林生財	2024.05.05

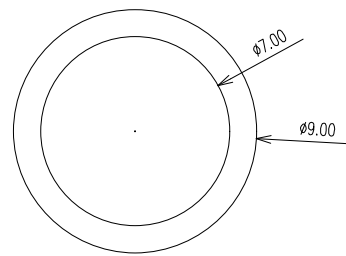
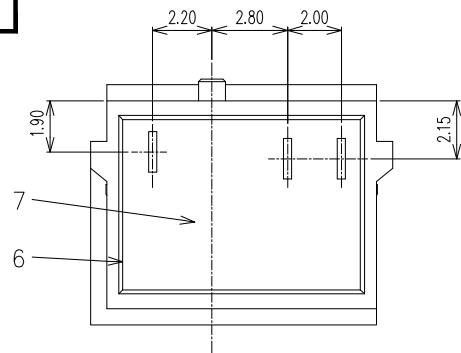

WHITE WATERPROOF RING

NOTES

- CURRENT RATING: 24V & 5A MAX.
- CONTACT RESISTANCE: 50mΩ MAX.
- INSULATION RESISTANCE: 100MΩ MIN.
- DIELECTRIC WITHSTANDING: 500V AC MIN.
- DURABILITY: 5000 CYCLES MIN.
- CONNECTOR MATING FORCES: 3~35N.
- CONNECTOR UNMATING FORCES: 3~35N.
- OPERATING TEMPERATURE: -25°C TO +85°C.

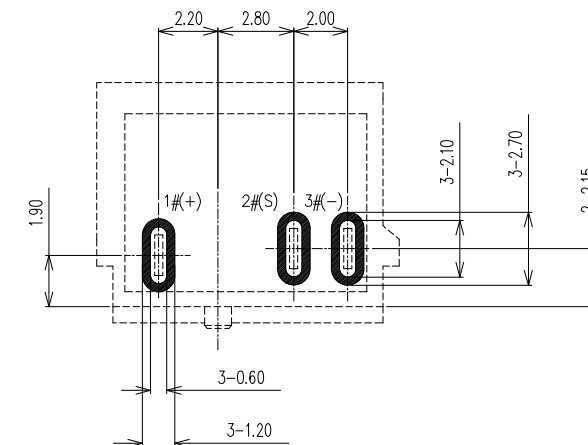

RECOMMEND PCB LAYOUT
TOLERANCE: ±0.05

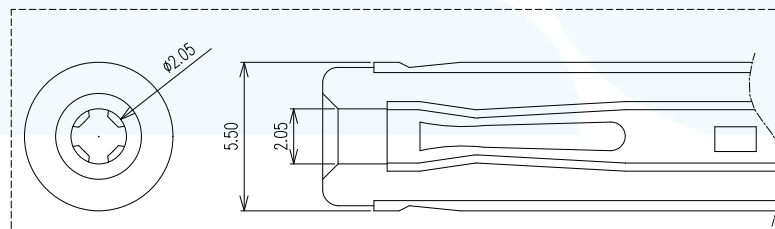
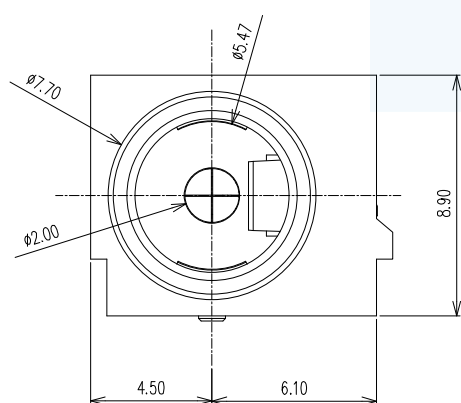
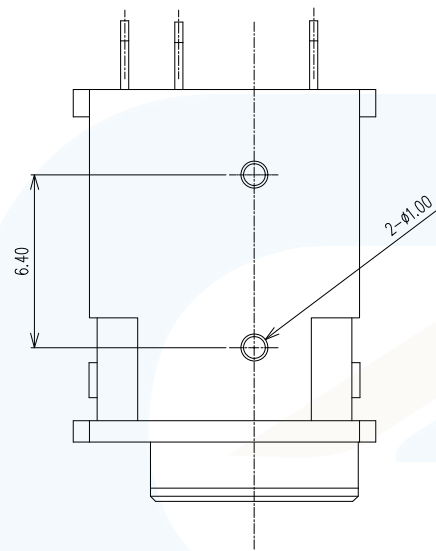
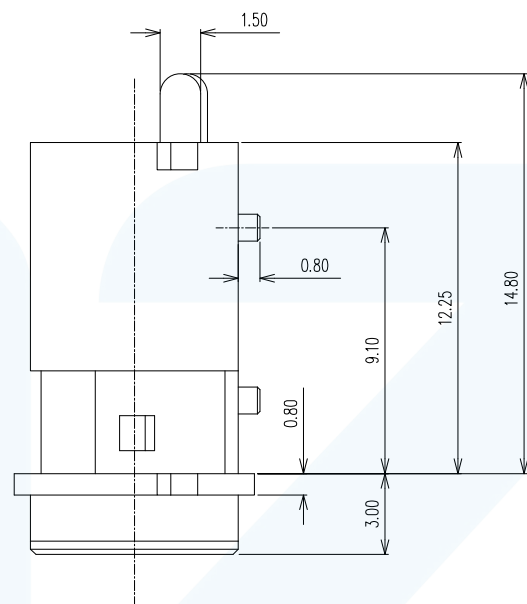
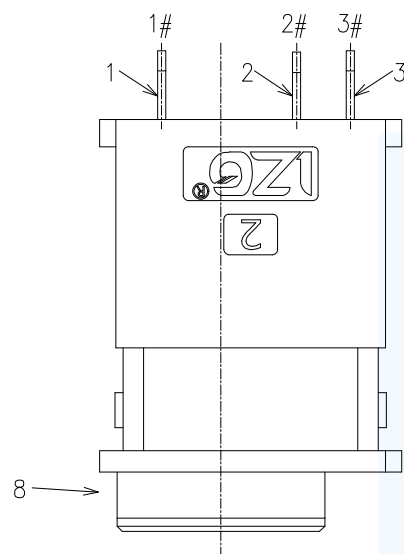
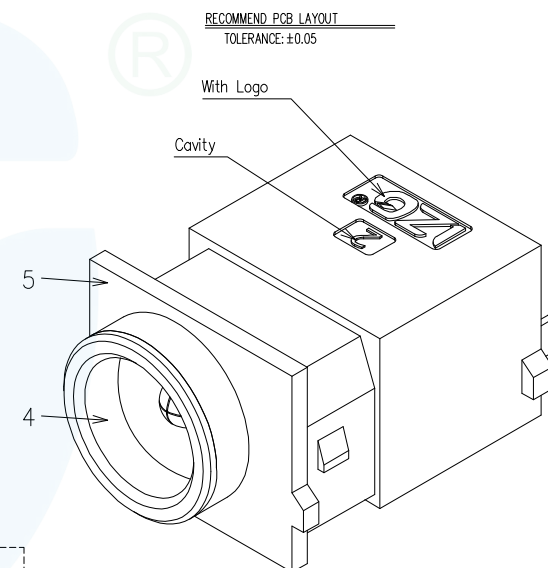

Not to install the waterproof ring shipment

Circuit Diagram

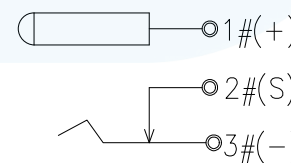

8	WATERPROOF RING	1	SILICONE; WHITE
7	GLUE	1	EPOXY; BLACK
6	BACK COVER	1	HIGH TEMPERATURE; BLACK
5	HOUSING	1	HIGH TEMPERATURE; BLACK
4	INNER BUSING	1	COPPER ALLOY; NICKEL PLATING
3	TERMINAL 3#	1	COPPER ALLOY; NICKEL UNDERPLATING OVERALL, Au PLATING ON SOLDER AREA
2	TERMINAL 2#	1	COPPER ALLOY; NICKEL UNDERPLATING OVERALL, Au PLATING ON THE WHOLE
1	TERMINAL 1#	1	COPPER ALLOY; NICKEL UNDERPLATING OVERALL, Au PLATING ON SOLDER AREA
ITEM	NAME	Q'TY	DESCRIPTION



LZG INDUSTRIAL CO. LTD

DRAWING:	林生財	DATE:	2024.05.05	SCALE	1:1
CHECK:	李宏鑫	DATE:	2024.05.05	MATERIAL	*
APPROVAL:	楊進宝	DATE:	2024.05.05	DWG. NO.	
DRAWING NO.	ZB30008-03DBAP-B			SHEET	1/1

PART NAME	02.0 WATERPROOF DC POWER JACK	TOLERANCE UNLESS OTHERWISE SPECIFIED:	0.0±0.30 0.0±0.20 0.000±0.10	0.°±2° 0.0°±1° 0.00°±0.5°	UNIT: mm	
PART NO.	ZB30008-03DBAP-B					